

X59T-LT Installation Guide

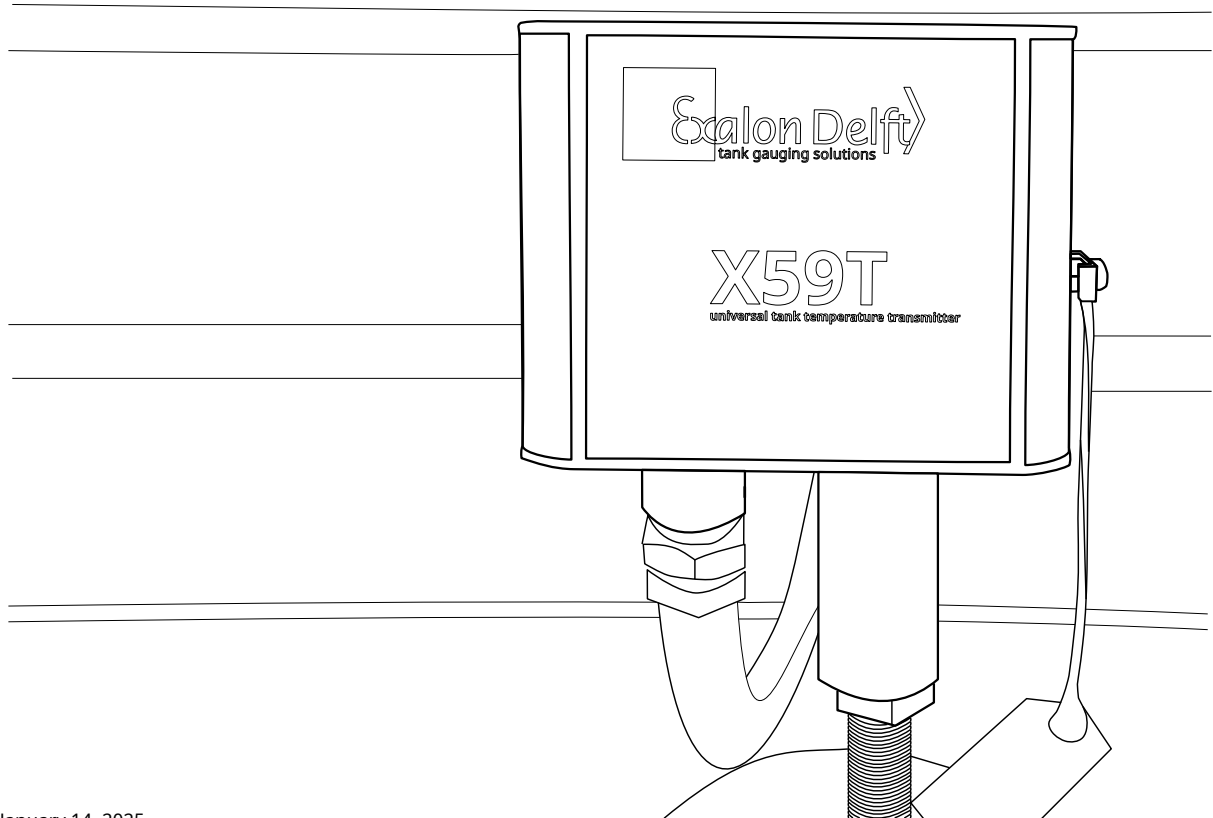

Table of Contents

1 Preface.....	4
1.1 Document conventions.....	4
1.2 Preface.....	4
1.3 Legal aspects.....	5
1.4 EU Declaration of Conformity.....	5
1.5 Additional information.....	5
2 Introduction.....	6
2.1 What is the X59T-LT?.....	6
2.2 Other X62T variants.....	7
3 Verification before installation.....	8
3.1 Instructions for use in potentially explosive atmospheres.....	8
3.2 Compatibility of the X59T-LT to Enraf gauge option boards.....	8
3.3 Compatibility of the X59T-LT to VITO LT probes.....	9
3.4 Determine mechanical dimensions.....	10
4 Installation.....	13
4.1 Powering the X59T-LT.....	13
4.2 Mechanical connection.....	13
4.3 Electrical connection the VITO LT temperature.....	14
4.3.1 Steps to Setup the X59T-LT for use with the VITO LT	15
4.3.2 Order Detection of Thermocouples	16
4.4 Electrical connection VITO LT water probe.....	16
5 Commissioning VITO LT temperature probe.....	18
5.1 Commissioning.....	18
5.2 Operation.....	19
5.3 Troubleshooting.....	20
5.4 Display Examples.....	22
6 Commissioning VITO LT water probe.....	24
6.1 Calibration.....	24
6.2 Commissioning.....	25
6.3 Operation.....	26
6.4 Troubleshooting.....	26

Table of Figures

Figure 1: Enclosure.....	6
Figure 2: X62T-VT installation.....	13
Figure 3: Connection of VITO LT probes.....	15
Figure 4: Connection of water probes.....	17

Index of Tables

Table 1: Option boards installed in the gauge and supported functions.....	9
Table 2: Supported MTT probes.....	9
Table 3: Mechanical dimensions.....	12
Table 4: Temperature status Byte 1.....	23
Table 5: Water status bytes.....	28

1 Preface

1.1 Document conventions

Warnings, Cautions and **Notes** are used throughout this installation guide to bring special matters to the immediate attention of the reader.

- A Warning concerns danger to the safety of the technician or user.
- A Caution draws the attention to an action which may damage the equipment.
- A Note points out a statement deserving more emphasis than the general text.

1.2 Preface

This installation guide is intended for technicians involved in the mechanical and electrical installation of the Exalon Delft X59T Interface. The technician must have basic technical skills and knowledge of safety regulations and explosion proof equipment in hazardous areas and must work in accordance with the (local) requirements for electrical equipment in hazardous areas.

Warning

In hazardous areas it is mandatory to use personal protection and safety gear such as:

hard hat, fire-resistive overall, safety shoes, safety glasses and working gloves.

Avoid possible generation of static electricity.

Use non-sparking tools and explosion-proof testers.

Make sure no dangerous quantities of combustible gas mixtures are present in the working area.

Never start working before the work permit has been signed by all parties.

Pay attention to the kind of product in the tank. If any danger for health, wear a gas mask and take all necessary precautions.

The X59T is installed external to storage tanks and converts temperature and capacitance parameters from sensors provided by third parties which are installed inside the storage tank. Please refer to the sensor manufacturers installation guide for details on installing the sensor inside the tank.

Warning

Do not use the instrument for anything else than its intended purpose.

Warning

Improper installation of cable glands, conduits or stopping plugs will invalidate the Ex approval of the X59T Interface.

Caution

The X59T Interface has intrinsically safe output/input circuits. Modifications to the instrument may only be carried out by trained personnel with written authorization from Exalon Delft. Unauthorized modifications will invalidate the approval certificate and impair safety.

1.3 Legal aspects

The mechanical and electrical installation shall only be carried out by trained personnel with knowledge of the requirements for installation of explosion proof equipment in hazardous areas.

The information in this installation guide is the copyright property of Exalon Delft B.V., Netherlands. Exalon Delft B.V. disclaims any responsibility for personal injury or damage to equipment caused by:

- Deviation from any of the prescribed procedures.
- Execution of activities that are not prescribed.
- Neglect of the general safety precautions for handling tools, use of electricity and microwave radiation.

The contents, descriptions and specifications are subject to change without notice. Exalon Delft B.V. accepts no responsibility for any errors that may appear in this installation guide.

1.4 EU Declaration of Conformity

This Exalon Delft instrument is in conformity with all applicable EU Council Directives, including the EMC Directive 89/336/EC and the ATEX114 Directive 2014/34/EC. Refer to the EUC Declaration of Conformity supplied with each instrument separately.

1.5 Additional information

Please do not hesitate to contact Exalon Delft or its representative if you require additional information.

2 Introduction

2.1 What is the X59T-LT?

The X59T is a Tank Thermometer transmitter based on the X62U multi-input HART transmitter with reduced number of terminals. With X59T-LT firmware installed it is a replacement for the Enraf 762 VITO LT transmitter supporting 9 spot VITO 767 and 768 probes only. The X59T-LT can be connected to Enraf servo gauges 854 ATG and 854 XTG, 873 and 97x Smartradar or 877 hydrostatic gauge that are fitted with HCU or HPI option boards as well as 990 Flexline radar and 954 Flexline servo with FII-VT option board (see Section 3.2).

The default /H enclosure has 2 PG16 entries:

- The cable entry allows a PG16 cable gland or adapter to be used (not supplied).
- The MTT entry is also PG16 with positioning hole compatible to Enraf MTT G1/2-G1/2 adapter. In a new installation or when replacing a Enraf 762 VITO you will require a Exalon Delft X62T-G1/2-M/F adapter (sold separately).

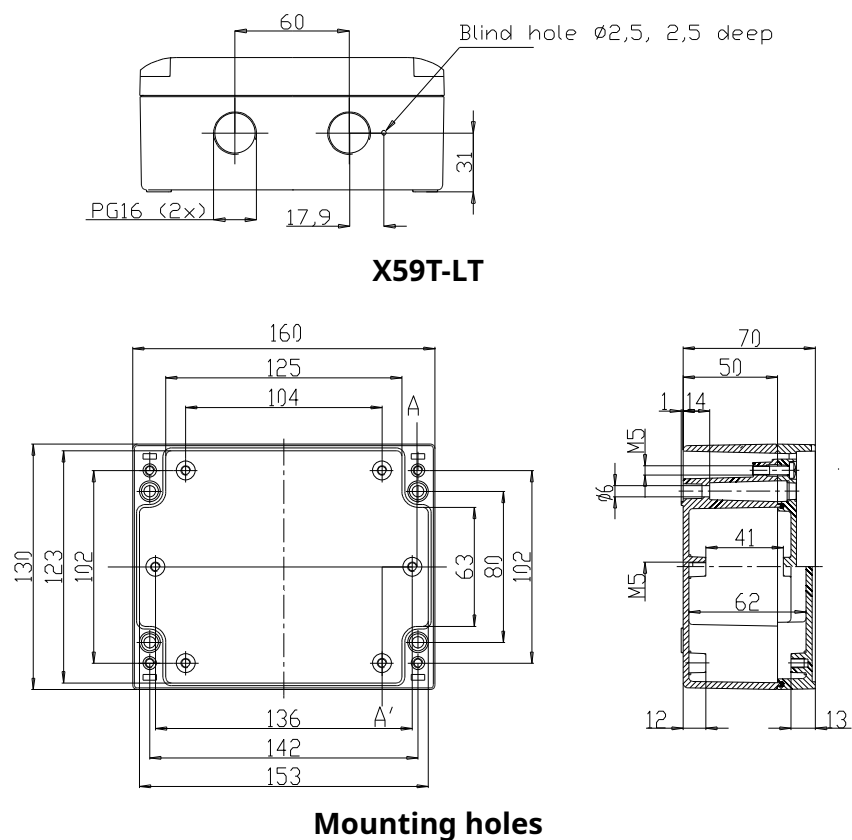

Figure 1: Enclosure

2.2 Other X62T variants

The X62T Host Interface and Probe Type are programmable. By supplying different firmware versions various combinations are supported to suite your application. See our Product Selection Guide at <https://www.exalondelft.nl/products/x62t/x62t-selection-guide> for a complete list.

3 Verification before installation

3.1 Instructions for use in potentially explosive atmospheres

This product is delivered with a printed 'Safety Instructions X62T/X59T' document. This document can also be downloaded from our website at <https://www.exalondelft.nl/products/x59t-x62t-documentation/>.

Before starting any task always read and understand the safety instructions document carefully and work in compliance with the instructions stated in it.

3.2 Compatibility of the X59T-LT to Enraf gauge option boards

The X59T-LT can be connected to Enraf servo gauges 854 ATG and 854 XTG, 873 and 97x Smartradar or 877 hydrostatic gauge that are fitted with HCU or HPI option boards as well as 990 Flexline radar and 954 Flexline servo with FII-VT option board to emulate Honeywell Enraf 762 VITO LT transmitters.

Note

Not all Honeywell Enraf option board versions support all functions. As the X59T-VT closely emulates 762 VITO LT the same limitations apply to the X59T-LT as to Honeywell Enraf 762 VITO LT interfaces.

Certain older versions of HCU/HPI firmware can only support the VITO but not the VITO LT (see Table 1: Option boards installed in the gauge and supported functions). If unsure what is supported by your HCU/HPI please contact your Honeywell Enraf representative.

Note

In this manual we will describe in detail how to connect X59T-LT to legacy Enraf gauges (854, 873, 97x) as for those documentation may be difficult to find. For connection to current Honeywell Enraf gauges (to FII-VT option board) refer to f.i. Honeywell "Service Manual 954 SmartServo Flexline", PN# 4417340

Internally in the gauge the HCU communicates with the XPU board. Depending on the XPU HW and SW version the HCU might be configured to emulate a MPU option board, which only supports VITO, but not VITO LT.

To find out the software version issue command SV.

Note
 To issue commands directly at the gauge you require a PET (Portable Enraf Terminal).
 Alternatively there are tools available to connect to the Enraf Fieldbus and issue commands to the gauge from the safe area.

Table 1: Option boards installed in the gauge and supported functions

Command	Example	Interpretation
SV	SV973 NVR1.0-- XPUK1.0-- APUB1.0 HCUA1.0	HCUA1.0 no VITO LT support
	SV854 NVR2.2-- XPUH2.4-- SPUB2.2 HCUA1.9	HCUA1.9 supports VITO LT
	SV973 NVR1.0-- XPUK1.0-- APUB1.0 MPUC121	MPU/HPU (emulation) no VITO LT support
	SV973 NVR1.0-- XPUK1.0-- APUB1.0 HSUC106	HSU (emulation) does not support VITO
VP=00.01	VVHCU CONFIG: 2E	HCU with option 0A 2E 1A 3F support VITO
VP=00.00	VVMPU HC-----	MPU emulation, no VITO connected
	VVHPU HC-----	HPU emulation, no VITO connected
	VVHSU HC--ST----	HSU emulation, no VITO supported
	VVMPU HC--MT----	MPU emulation, VITO detected
	VVHCU HC--MTWT--	HCU mode, VITO + VITO water bottom probe detected

When supported by the XPU preferably select HCU mode instead of MPU or HPU emulation. Selection is done by jumpers on the option board. Please refer to the Honeywell Enraf manual on changing emulation type.

3.3 Compatibility of the X59T-LT to VITO LT probes

The X59T-LT supports the same VITO LT probes as the 762 VITO LT (see Table 2: Supported MTT probes).

You can identify a compatible probe from the identification code on the type plate:

□□□□**YYYX**□□□**0**□□□□**0**

Table 2: Supported MTT probes

YYY	X	Description
767	C	9 spot temperature probe, Pt100 is the lowest spot at 1m from probe bottom.
767	D	9 spot temperature probe. Pt100 is the second spot at 1m from the probe bottom. Lowest spot at 65mm from probe bottom.

YYY	X	Description
768	C	Combined water and 9 spot temperature probe. Pt100 is the lowest spot, location see table.
768	D	Combined water and 9 spot temperature probe. Pt100 is the second spot, location see table. Lowest spot at probe bottom.
765	*	VITO Water probe only – not supported.
863		MRT probe – not supported.
361		MPT probe – not supported.
365		Combined MPT and Water probe – not supported.

When the Pt100 is the second spot, the lowest spot is a thermocouple. This lowest thermocouple spot is always wired with an ORANGE wire. With an ORANGE wire present, the probe type is D.

3.4 Determine mechanical dimensions

Mechanical dimensions can be determined from the VITO LT probe type identification plate. You will need these dimensions to configure the gauge correctly.

- The sensitive length is always measured from the position of the Pt100 to the highest element. This will be needed to configure item MK in the gauge.
- The lowest spot position is measured from the bottom of the probe to the center of the lowest spot element. This will be needed to configure item MO in the gauge. Item MO is configured as the height from Tank Zero to the position of the lowest element. As a result, the height from tank zero to the bottom of the VITO LT needs to be added to the position of the lowest spot element (see Table 3: Mechanical dimensions).

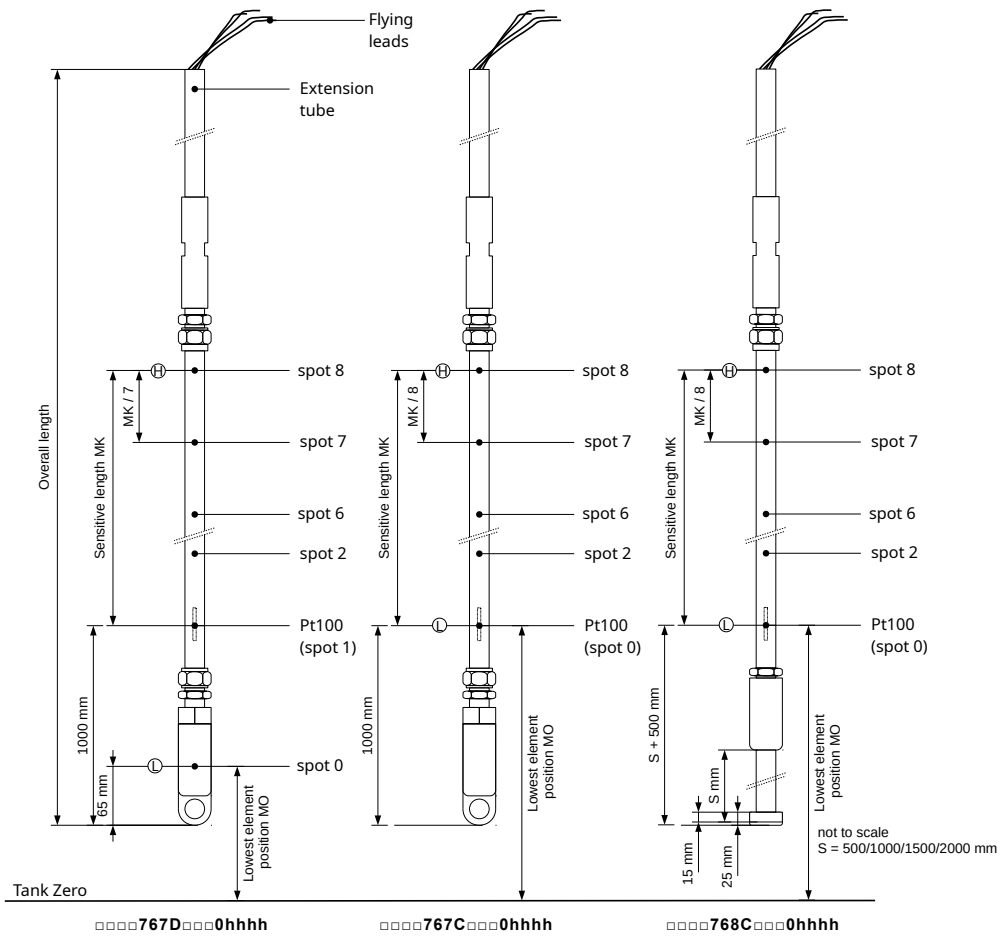

Table 3: Mechanical dimensions

	Water probe sensitive length WP	Lowest spot element position MO	Pt100 position	Temperature sensitive length MK
768C combined probe				
□A□□768C□□□0hhhh	485mm	1000mm	1000mm	hhhh - 100 [cm]
□B□□768C□□□0hhhh	985mm	1500mm	1500mm	hhhh - 150 [cm]
□C□□768C□□□0hhhh	1985mm	2500mm	2500mm	hhhh - 250 [cm]
768D combined probe				
□A□□768D□□□0hhhh	485mm	65mm	1000mm	hhhh - 100 [cm]
□B□□768D□□□0hhhh	985mm	65mm	1500mm	hhhh - 150 [cm]
□C□□768D□□□0hhhh	1985mm	65mm	2500mm	hhhh - 250 [cm]
767 temperature probe				
□□□□767C□□□0hhhh	0	1000mm	1000mm	hhhh - 100 [cm]
□□□□767D□□□0hhhh	0	65mm	1000mm	hhhh - 100 [cm]

To verify if the correct values have been entered you can check the values of U8 (9 element probe). This item contains the position of the highest element (without MO having been added).

4 Installation

4.1 Powering the X59T-LT

The X59T can be configured to draw a constant current of either 5,5 mA or 17,5 mA. Preferably the low current mode should be selected (SW1 BROWN in OFF position).

In low current mode the X59T requires a voltage between 12V and 24V on the terminals CN1-1 and CN1-3 and larger than 14V in high current mode. When connected to an Enraf HCU or HPI option board in low current mode the supply voltage will always be sufficient (> 16V).

Note

The HCU/HPI has 2 HART channels. Channel 2 will deliver only 12.5V with the X59T-LT in high current mode. Select low current to operate on Channel 2.

Note

Issuing a reset command to the gauge (RS) will temporarily cut power and RESET the X59T.

4.2 Mechanical connection

To mount the X59T enclosure on the VITO MTT adjusting pipe you require X62T-G1/2-M/F adapter (sold separately). Alternatively you can use a Enraf G1/2-G1/2 M/F as used to mount 862 MIT transmitters.

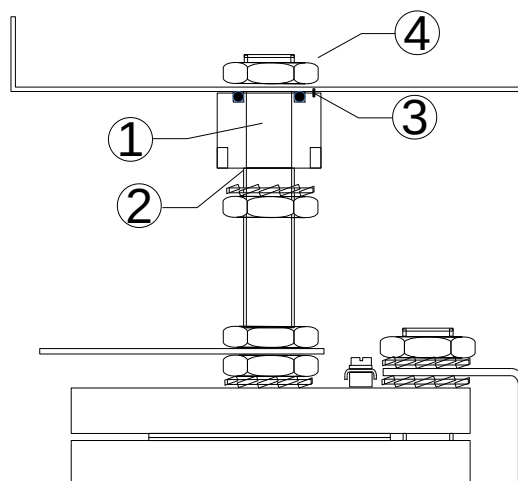

Figure 2: X62T-VT installation

- If necessary remove the 762 VITO LT from the VITO MTT adjusting pipe (2). It may be necessary to use a large amount of force. Note that excessive force can

cause the 762 VITO LT enclosure to break. Follow Honeywell Enraf de-installation instructions if unsure.

- Open the cover from the X62T enclosure.
- Remove the X62U from the enclosure.
- Place the empty X62T enclosure on top of the adapter (1) carefully positioning the position pin (3) in the enclosure blind hole.
- Secure the X62T enclosure using the half height G1/2 hexagon nut (4) and supplied shake proof washer until the O-ring is fully compressed and the enclosure will not be able to move.
- Turn the SS G1/2 hexagon nut onto the adjusting pipe (2) until 50mm of thread is free and place the SS shake proof washer.
- Feed the MTT wiring through the G1/2-G1/2 M/F adapter (1).
- Apply a suitable thread locking pipe sealant on the first 25mm of the MTT adjusting pipe (2).
- Turn the adapter (1) tightly onto the adjusting pipe (2) using a wrench on the adapter (3). Tighten the SS hex nut.

Caution

Do not attempt to tighten by applying force to the enclosure as this will damage the positioning pin.

4.3 Electrical connection the VITO LT temperature

- Connect VITO LT probes according to Figure 3: Connection of VITO LT probes.

Caution

Discharge tools to the tank before bringing into contact with the X59T terminals to prevent ESD (electrostatic discharges). Then FIRST connect one BROWN wire to terminal 3 on CN3. Damage due to ESD related events are not covered by the warranty.

Connect blue wires to the terminals with blue color in the drawing, yellow to the yellow terminal, etc.:

- If an orange wire is present connect this to terminal 19 of CN3 and set SW2 RED to ON.

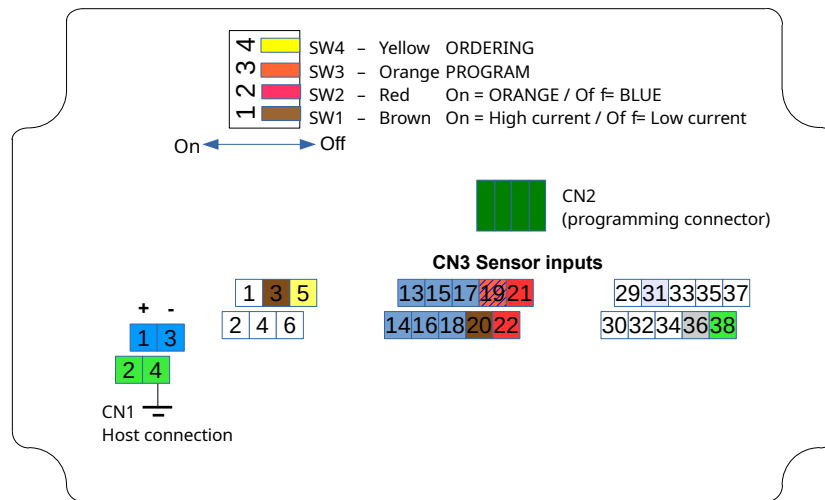

Figure 3: Connection of VITO LT probes

4.3.1 Steps to Setup the X59T-LT for use with the VITO LT

- Set switch SW1 BROWN in Off position to enable low current mode.
- Set switch SW2 RED in Off position if there is NO ORANGE wire, ON if there IS an ORANGE wire.
- Set switch SW3 ORANGE in Off position to have the X59T start in Run Mode.
- Enable order detection of the thermocouples by setting switch SW4 YELLOW in On position. See the next section for details.
- Turn power of X59T on. Wait for 3 minutes minimum to perform the order detection.
- Turn power of X59T off and set switch SW4 YELLOW in Off position. All other switches need to be left in their current positions.

After the order detection is complete temperature should be indicated on the display or the PET.

Example

The display indicates +023.97FL ---I1 meaning temperature has been detected but the gauge needs configuration.

Example

The PET item AP = IF@@9999999 meaning temperature is not ready.

AP = C@@@+023.97 indicates correct temperature, with C = '0' - 'F' indicating the highest submerged spot element.

4.3.2 Order Detection of Thermocouples**Note**

With 762 VITO LT the detection of the connection order is done by the HCU/HPI on each startup. The result is that when one of these wires is broken the order cannot be detected and temperature measurement status will show a failure.

For improved reliability in the X59T-LT order detection is done once during commissioning and the results are stored in the X59T-LT non-volatile memory. The connection order of the blue wires and the therefore the position of the spots is presented to the HCU/HPI in the correct order. The result is that the X59T-LT will always measure all spots that are correctly connected.

The Blue thermocouples of the VITO LT can be connected in any order. Using the Yellow switch SW4 the X59T can be configured to determine the connection order during power-up. This can take up to 2 minutes.

After detection the X59T stores the detected order in internal persistent storage (EEPROM) and uses this for operation. Once the correct connection order has been determined and stored turn off Ordering using SW4 YELLOW.

As the order of wires is stored in EEPROM the X59T will continue to function after power-up, even when a LT wire is broken and automatic order detection is no longer possible.

Note

After connecting or reconnecting LT wires the order of the Blue wires will most likely be changed and the correct thermocouple order must be re-detected. To make the X59T re-determine the order set switch SW4 YELLOW (Ordering) in position 'On' and turn the gauge power off and on or issue an RS command using the PET.

4.4 Electrical connection VITO LT water probe

The X59T-LT does not support VITO water probe only types. Only combined temperature and water probes are supported. See 3.3 Compatibility of the X59T-LT to VITO LT probes for the supported type codes on the type identification plate.

- Connect the LT or VITO LT Combined water and temperature probes according to Figure 4: Connection of water probes.

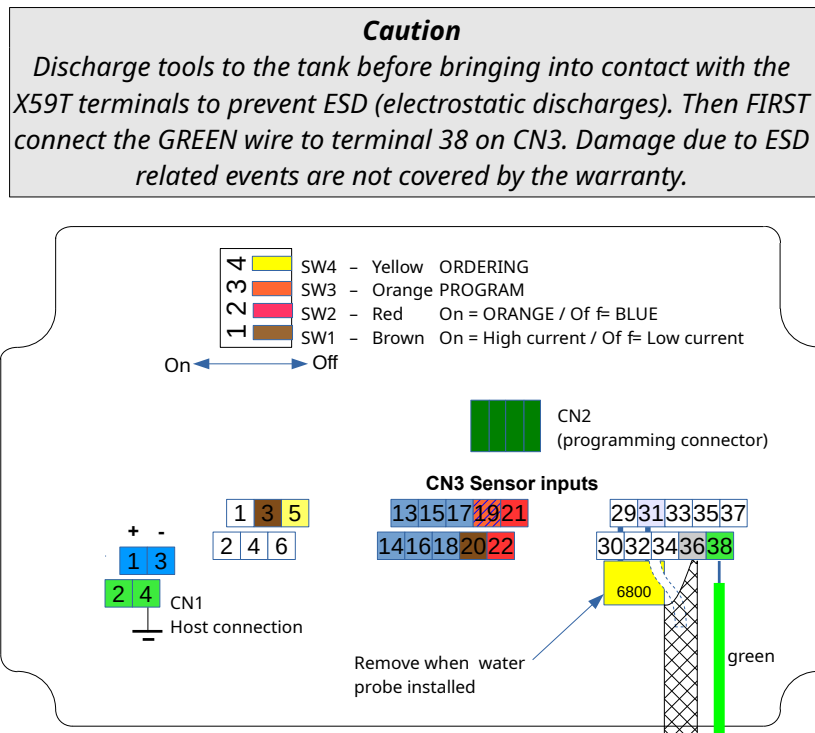
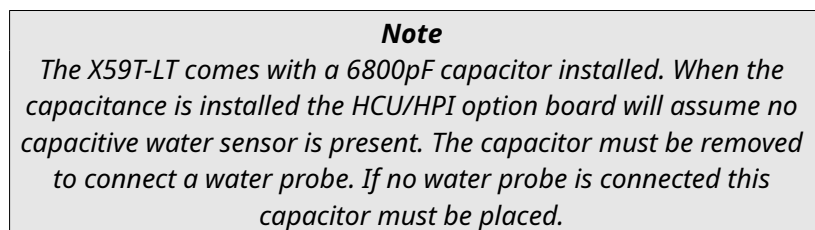

Figure 4: Connection of water probes



- Remove the capacitor from terminal 29 (GND) and 31 of CN3
- Connect the GREEN wire to terminal 38 of CN3 (GND)
- Connect the cable shield to terminal 36 of CN3 (Active guard)
- Connect the cable core to terminal 31 of CN3 (Capacitance input C1)

5 Commissioning VITO LT temperature probe

5.1 Commissioning

The following settings are intended to set up temperature measurement quickly, for settings customized to your local installation please consult your gauge manual or download the document *“Item documentation for Honeywell Enraf series 854 Level Gauges, 97x series SmartRadars Gauges and 877 Field Display & Interface”*, Part no.: 4416277 from <http://www.honeywellprocess.com>.

Item	Name	Description
W2	Protection level 2	Default W2=ENRAF2
TD	Temperature dimension	Default TD=C (Celsius)
MT	Element type	MT=TPL
MR	Reference Resistance	+ .22200000E+03
MK	Sensitive length temperature probe	Use the value from Table 3: Mechanical dimensions. Default MK=+030.0000 (m)
MO	Temperature element offset	Use the value from Table 3: Mechanical dimensions. Default MO=+000.0000 (m)
MI	Switch hysteresis	Default MI=+000.1000 (m)
MP	Product immersion depth	Default MP=+000.5000 (m)
MG	Gas immersion depth	Default MG=+000.5000 (m) for 854, 97x Default MG=+000.1000 (m) for 877
WP	Water probe length	Use the value from Table 3: Mechanical dimensions. Default WP=+001.0000 (m)
MJ	Temperature distribution	Disables the lowest element from the average temperature calculation. This is necessary to comply with API and ISO recommendations that the lowest element used for average temperature calculation is positioned 1m from the bottom of the tank. If the product level drops below 1m the lowest element will be used to calculate the average product temperature. The temperature status 'level below lowest element' will be set. If MO is less than 1m MJ should be set to F if you

Item	Name	Description
		require API/ISO compliance. This item is implemented in HCU/HPI firmware A1.8 or higher and is not yet documented in the "Item documentation ..." rev. 5 (August 2013). For older firmware use MW.
MW	MTT wiring connection	Default MJ=F (lowest element disabled) Alternative MJ=C (lowest element enabled) Only set this item for HCU/HPI firmware before A1.8 when MO is less than 1m.
TU	Temperature status conversion	Setting this will disable the lowest element. Default MW=0000000000000000 (all elements enabled) Alternative MW=F000000000000000 (lowest element disabled) The character used to indicate a reduced accuracy for the temperature status caused by: <ul style="list-style-type: none"> • temperature out of range • temperature gradient out of range • last valid level used • manual level used • level below the lowest element Default TU=T
EX	Exit	

Additional temperature settings may apply for the 877 FDI. Please refer to the document *"Instruction manual VITO interface and average temperature (and water) probes for 854 servo, 97x SmartRadar and 877 FDI"*, Part no.: 4416.655 from <http://www.honeywellprocess.com> for more information.

5.2 Operation

If the gauge is equipped with a display, depending on the selected display format a correct temperature measurement will show the temperature followed by the selected unit of temperature 'C' or 'F' (example: +027.13°C ---I1). Incorrect temperature may show FL (example +023.97FL ---↓I1).

Without display, temperature related data may be retrieved using the PET.

Item	Name	Description
AP	Average product temperature	The temperature is preceded by 4 status bytes. The first byte indicates the highest submerged spot element ('0' ... 'F'). During startup it will be 'I'. Under normal operation the remaining three status bytes will be '@'
AG	Average gas temperature	Same as AP.
EM	Temperature system error	Last encountered error. If no errors after initialization will be: 2200 (MPU emulation) 2400 (HPU emulation) 3000 (HCU emulation)
MU	Value of the X62T test resistor	166.5Ω ± 0.03% when EM shows no errors
U0 - UF	Relative spot position	As calculated by the gauge without adding item MO
V0 - VF	Spot temperature	Temperature of the spot (V0 is the lowest spot) preceded by the temperature status (same as AP).

5.3 Troubleshooting

The X59T-LT firmware measures all MTT Pt100 and thermocouple elements independently from the HCU/HPI option board. Errors are detected in a much earlier stage than with the 762 VITO namely when calculating the resistance and voltages from the individual sub-measurements and before communicating the end result to the HCU/HPI.

Further, the X59T-LT orders the thermocouple wires prior to sending the measurement results to the HCU/HPI. As a result the HCU/HPI does not know the real connection order to the X59T-LT and item RW will always shows the spots ordered '0123456789ABCDEF'.

For diagnostic purposes the X59T-LT provides the following mechanism:

- A X59T hardware failure purposely generates a large error shown in the value of the measured internal test resistor. The value is transmitted to the gauge to item MU and will cause a fatal error in the temperature measurement system in the HCU/HPI.
- A non-fatal error in an LT element measurement is indicated generating temperature out of range error for that element only in the HCU/HPI.

Step	Check	Description	Next
1	Check display unit C or F	An invalid temperature on the display will not have the temperature unit and 'FL' may be shown.	3
	or Check AP status=x@@@	x indicates the highest submerged spot. @@@ indicates no errors or warnings. See Table Table 4 Temperature status Byte 1 .	
2	Check EM		
	xx00	No last error available.	3
	xx11	No initial communication.	4
	xx92 xx70	Communication interrupted. Subsystem error.	
	xx51-xx64	Spot 1-14 not connected (non fatal).	5
	xx65	Spot 0 or 15 not connected.	6
	xx80	Rtest error, X59T-LT signals a fatal error.	7
3	MU V0 - VF	Value of the X59T test resistor $166.5\Omega \pm 0.03\%$. Temperature of the spot (V0 is the lowest spot) preceded by the temperature status (as AP).	Stop
4	Check voltage on CN1 1-3	> 14V. See 4.1 Powering the X59T-LT.	End
		Set SW1 to low current or correct wiring to HCU/HPI.	
5	Check MU	MU=+.1665ttxx, with tt ¹ the terminal on CN3.	End
		If the wire can not be repaired disable the spot using item MW.	
6	Check V0	If V0 shows a temperature, spot 15 is not wired correct (non fatal if ordering complete). If the wire can not be repaired disable the spot using item MW.	
	Check MU	MU=+.1665ttxx ¹ , with tt the terminal on CN3. Correct the wiring.	End

¹ ttxx may need to be rounded to the nearest value.
Example: +.16651999E+03 refers to terminal 20.

Step	Check	Description	Next
7	Check MU	<p>If MU < 64², MU is the sum of</p> <ul style="list-style-type: none"> 1 Internal power supply failed 2 Internal power supply failed 4 Internal power supply failed 8 Internal Test Resistance failed 16 Internal Test Capacitance failed 32 Internal Test Capacitance failed <p>Example: MU=+.69999995E+01 nearest integer 7 = 1 + 2 + 4, all internal power supplies failed.</p> <p>If MU 180 ... 183 there is a Pt100 wiring error.</p> <ul style="list-style-type: none"> 180 BROWN wire on CN3-20 is disconnected 181 RED wire on CN3-21 is disconnected 182 RED wire on CN3-22 is disconnected 183 BROWN wire on CN3-3 is disconnected (CN3-3) <p>If MU 184 ... 185 there is an EMC error.</p> <ul style="list-style-type: none"> 184 EMC error, to much noise 185 EMC error, to much noise <p>If MU 205 ... 223 there is a wiring error. Ordering can not complete due to a disconnected spot (fatal), with tt the terminal on CN3.</p> <ul style="list-style-type: none"> 2tt tt not connected 223 GND wire not connected <p>Correct the wiring.</p> <p>If MU 200 the wiring error has been resolved. Reset the gauge.</p>	End
<hr/>			
End	Contact Exalon Delft for support		

5.4 Display Examples

When all temperature measurements succeeded the display will show for example

```
+009.3121 m INN
+025.71°C ----I1
```

2 Round MU in Enraf floating point format +.mmmmmmmmE+ee to the nearest integer

Then MU would be +.16650675E+03 and EM would be 2200.

When Spot 1 on T5 is disconnected the display will show for example

```
+009.3120 m INN
+025.74FL ----I1
```

where FL indicates 'General MPU/HPU fail'. Then MU would be +.166505000E+03 and EM would be 2289.

When the PT100 wire on T22 is disconnected the display will show for example

```
+009.3120 m INN
+999.99FL ----I1
```

where FL indicates 'General MPU/HPU fail'. Then MU would be +.18200000E+03 and EM would be 2280.

Table 4: Temperature status Byte 1

	Spot element fail (one or more spots defect)	Level exceeds highest spot element	Level exceeds lowest spot element	Fail in average gas temperature	Fail in average product temperature	General temperature fail
@	0	0	0	0	0	0
A	0	0	0	0	0	1
B	0	0	0	0	1	0
C	0	0	0	0	1	1
D	0	0	0	1	0	0
E	0	0	0	1	0	1
F	0	0	0	1	1	0
G	0	0	0	1	1	1
H	0	0	1	0	0	0
I	0	0	1	0	0	1
J	0	0	1	0	1	0
K	0	0	1	0	1	1
L	0	0	1	1	0	0
M	0	0	1	1	0	1
N	0	0	1	1	1	0
O	0	0	1	1	1	1
P	0	1	0	0	0	0
Q	0	1	0	0	0	1
R	0	1	0	0	1	0
S	0	1	0	0	1	1
T	0	1	0	1	0	0
U	0	1	0	1	0	1
V	0	1	0	1	1	0
W	0	1	0	1	1	1
X	0	1	1	0	0	0
Y	0	1	1	0	0	1
Z	0	1	1	0	1	0
[0	1	1	0	1	1
\	0	1	1	1	0	0
]	0	1	1	1	0	1
^	0	1	1	1	1	0
_	0	1	1	1	1	1
`	1	0	0	0	0	0
a	1	0	0	0	0	1
b	1	0	0	0	1	0
c	1	0	0	0	1	1
d	1	0	0	1	0	0
e	1	0	0	1	0	1
f	1	0	0	1	1	0
g	1	0	0	1	1	1
h	1	0	1	0	0	0
i	1	0	1	0	0	1
j	1	0	1	0	1	0
k	1	0	1	0	1	1
l	1	0	1	1	0	0
m	1	0	1	1	0	1
n	1	0	1	1	1	0
o	1	0	1	1	1	1
p	1	1	0	0	0	0
q	1	1	0	0	0	1
r	1	1	0	0	1	0
s	1	1	0	0	1	1
t	1	1	0	1	0	0
u	1	1	0	1	0	1
v	1	1	0	1	1	0
w	1	1	0	1	1	1
x	1	1	1	0	0	0
y	1	1	1	0	0	1
z	1	1	1	0	1	0
{	1	1	1	0	1	1
	1	1	1	1	0	0
}	1	1	1	1	0	1
~	1	1	1	1	1	0
	1	1	1	1	1	1

6 Commissioning VITO LT water probe

The following settings are intended to set up water bottom measurement quickly. For settings customized to your local installation please consult your gauge manual or download the document *"Item documentation for Honeywell Enraf series 854 Level Gauges, 97x series SmartRadars Gauges and 877 Field Display & Interface"*, Part no.: 4416277 from <http://www.honeywellprocess.com>.

6.1 Calibration

For a quick setup the Honeywell Enraf factory calibration values for the maximum and minimum capacity of the water probe are listed on the "Checklist 765/766/768 Final Assembly", delivered with every VITO water probe.

As these values are influenced by the actual installation using the factory calibration values will negatively impact water bottom accuracy. A system calibration on-site is highly recommend for best accuracy.

For the detailed probe calibration procedure refer to Appendix B of Honeywell Enraf document *"Instruction manual VITO interface and average temperature (and water) probes for 854 servo, 97x SmartRadar and 877 FDI"*, Part no.: 4416.655 from <http://www.honeywellprocess.com> for more information.

To calibrate item VR we recommend following "Situation 2 (probe fully covered with product)" where possible as during installation it is in many cases possible to temporarily position the probe in the tank at such a height that it is fully covered with product. This can be achieved for instance by elevating the bottom of the water probe above the water level in the tank (assuming there is little or no water present). This procedure allows item VR to be easily determined by retrieving the value from item MX.

When no water is present in the tank item VT can not be calibrated and the value from the "Checklist 765/766/768 Final Assembly", delivered with every VITO water probe should be used (see Note below).

When the water level exceed 10cm additionally Situation 3 (probe partly covered by water and partly covered by product) should be followed. The water level should be measured using a manual dip. The VR can be calculated as follows:

$$\% \text{ water} = \frac{\text{Water level} - \text{WB}}{\text{WP}},$$

$$VT = \frac{MX - VR}{\% \text{ water}/100} + VR ,$$

with VR and MX read by the PET or the service program.

Example:

The probe bottom is positioned on the tank floor, the sensitive part of the probe starts 25mm above the bottom end. Therefore item WB = 25mm. The probe sensitive length = 485mm (see Table Table 3). A manual dip shows 100mm water is present. Retrieving VR (as calibrated before) from the gauge shows 120.93pF, and MX is 168.786pF.

Now,

$$\% \text{ water} = (100 - 25) / 485 \times 100\% = 15.464\%$$

$$VT = (168.786 - 120.93) / 0.15464 + 120.93 = 430.4\text{pF}.$$

Note

Item VT does not depend strongly on the position of the water probe in the tank.. It does however depend on the internal reference capacitor of the X59T-LT.

*Without calibration of item VT the accuracy of the water level (item LW) is 2% of the measured value (M.V). Although not stated in the VITO Instruction Manual this is the same for the 762 VITO.
With proper calibration the X59T-LT can achieve an accuracy of $\pm 0.1\% \text{ M.V} \pm 1\text{mm}$.*

After calibration be sure to record the calibration values for VR and VT in a secure place as they might be erased in the gauge in case it needs to be initialized to factory settings in the future.

6.2 Commissioning

The following settings are intended to set up water bottom measurement quickly, for settings customized to your local installation please consult your gauge manual or download the document “*Item documentation for Honeywell Enraf series 854 Level Gauges, 97x series SmartRadars Gauges and 877 Field Display & Interface*”, Part no.: 4416277 from <http://www.honeywellprocess.com>.

Item	Name	Description
W2	Protection level 2	Default W2=ENRAF2
VR	Capacitance at 0% water	In pF. See 6.1 Calibration. Default +.00000000E+00

Item	Name	Description
VT	Capacitance at 100% water	In pF. See 6.1 Calibration. Default +.00000000E+00
WB	Water probe bottom position	The height from tank zero to the bottom end of the probe + 25 mm.
WP	Water probe length	Use the value from Table 3: Mechanical dimensions. Default WP=+001.0000 (m)
WF	Water level field communication	Only for 854 level gauges. Default: D. Sends displacer water dip to the system. Alternative: S. Sends water probe to the system.
WH	Water high alarm	Sets water high alarm. Default: +000.0000 m.
WL	Water low alarm	Sets water low alarm. Default: +000.0000 m.
WS	Water alarm hysteresis	The amount the water level must drop after reaching the high alarm or rise after reaching the low alarm to turn of the alarm. Default: +000.0100 m
EX	Exit	

6.3 Operation

Item	Name	Description
LW	Water innage	2 status bytes, followed by water level. Example: @@+000.0244
LH	Water ullage	2 status bytes, followed by water ullage
MX	Measured capacitance	The probe capacitance in pF.
EW	Water measurement error	Last encountered error. If no errors after initialization will be: 2200 (MPU emulation) 2400 (HPU emulation) 3000 (HCU emulation)

6.4 Troubleshooting

For a detailed description of HCU/HPI error codes refer to Chapter 5.4 of Honeywell Enraf document *"Instruction manual VITO interface and average temperature (and*

water) probes for 854 servo, 97x SmartRadar and 877 FDI", Part no.: 4416.655 from <http://www.honeywellprocess.com> for more information.

Step	Check	Description	Next
1	Check LW status=@@	An invalid water level with @@ indicates no errors or warnings. See Table Table 5 Water status bytes.	4
2	Second status byte = A	Water probe not detected during startup.	5
3	First status byte shows General Probe Fail (Table 5: Water status bytes)	Water probe detected during startup, but disconnected or shorted to GND later.	6
4	LW MX	LW shows the water level. MX shows the measured capacitance between VR and VT.	Stop
5	EW	3005 No probe connected to CN3-31 3098 Dummy capacitor connected to CN3-31 or probe shorted to GND. Repair connection.	End
6	EW	3005 Probe no longer connected to CN3-31 3006 Probe capacitance higher than maximum allowed or probe shorted to GND. Repair connection.	End
End	Contact Exalon Delft for support		

Table 5: Water status bytes

Status byte 0						Status byte 1					
			Water above probe warning								
			Water below probe warning								
			High water alarm								
			Low water alarm								
			General probe fail								
@	0	0	0	0	0	P	1	0	0	0	0
A	0	0	0	0	1	Q	1	0	0	0	1
B	0	0	0	1	0	R	1	0	0	1	0
C	0	0	0	1	1	S	1	0	0	1	1
D	0	0	1	0	0	T	1	0	1	0	0
E	0	0	1	0	1	U	1	0	1	0	1
F	0	0	1	1	0	V	1	0	1	1	0
G	0	0	1	1	1	W	1	0	1	1	1
H	0	1	0	0	0	X	1	1	0	0	0
I	0	1	0	0	1	Y	1	1	0	0	1
J	0	1	0	1	0	Z	1	1	0	1	0
K	0	1	0	1	1	[1	1	0	1	1
L	0	1	1	0	0	\	1	1	1	0	0
M	0	1	1	0	1]	1	1	1	0	1
N	0	1	1	1	0	^	1	1	1	1	0
O	0	1	1	1	1	_	1	1	1	1	1

	Water probe not present
@	0
A	1

Exalon Delft BV Radex Innovation Center Rotterdamseweg 183C 2629 HD Delft The Netherlands Tel: +31(15)2682554 Fax: +31 (84)8337893 E-mail: info@exalondelft.nl	Authorized local distributor/reseller
--	--

Exalon Delft is not affiliated with Honeywell Enraf in any way. VITO® is a registered trade mark of Honeywell Enraf. Information in this publication is believed to be correct at the time of writing. Exalon Delft reserves the right to change this information without notice.